



SMARTSIDE®
TRIM & SIDING

ARCHITECTURAL COLLECTION PRIMED BOLD PROFILE 120 SERIES LAP SIDING (D5, T4, D8, T5, Q4)

GENERAL

- At the time of manufacture, siding meets or exceeds the performance standards set forth in Composite Panel Association ANSI 135.6-2006 and has achieved code recognition under Legacy National Evaluation Report NER-626 and CCMC-12353L. For copies of these reports, call LP Customer Support at 1-800-577-4836.
- Minimum 6 in. clearance must be maintained between siding and finish grade.
- Siding applied adjacent to porches, patios, walks, etc. must have a clearance of at least 1 in. above any surface.
- Minimum 1" clearance at intersection with roof line
- Apply siding in a manner that prevents moisture intrusion and water buildup.
- All exposed wood substrate must be sealed in a manner that prevents moisture intrusion and water buildup.
- In non-traditional ICF and SIP assemblies, the ICF or SIP manufacturer must prescribe the fastening specifications. Note: LP does not recommend LP SmartSide for use in these non-traditional assemblies. If used, LP will not warrant for Buckling and Shrinkage. However, balance of warranty does remain intact.
- When using wet blown cellulose insulation, the insulation must not be in direct contact with the siding and it must be allowed to dry a minimum of 24 hours or longer if specified by the insulation manufacturer.
- DO NOT USE STAPLES
- Siding must not contact masonry.

STORAGE

- Store off the ground well supported, on a flat surface, under a roof or separate waterproof covering
- Keep siding clean and dry. Inspect prior to application.
- Allow siding to adjust to atmospheric conditions before application.

STUD SPACING

- Architectural Collection 120 series Bold Profile Lap Siding may be applied over sheathed walls or where building codes permit, directly to studs spaced no greater than 16" O.C. that have adequate corner bracing.
- In all installations over masonry walls, the wall must be furred out and open at top and bottom to allow for convective ventilation with framing spaced 16 in. O.C. and with adequate thickness to accept the full length of the recommended nail.

MOISTURE

- Moisture control and moisture vapor control are critical elements of proper housing design. Check your local building codes for application procedures for handling moisture and moisture vapor in your area.
- As with all wood products, do not apply engineered wood siding to a structure having excessive moisture conditions such as drying concrete or plaster. If such conditions exist, the building should be well ventilated to allow it to dry prior to the application of the siding.
- Siding must not be applied to green or crooked structural framing members. Do not apply siding over rain-soaked or buckled sheathing materials.
- Gutters are recommended for control of roof water run off.

SECONDARY WEATHER RESISTANT BARRIER

- A properly installed breathable water-resistive barrier is required behind the siding.
- Consult your local building code for details.
- LP will assume no responsibility for water penetration.

GAPS & SEALANTS

- Seal all gaps with a high-quality, non-hardening, paintable sealant with a minimum stated service life of 30 years. Follow the sealant manufacturer's instructions for application.

FLASHING, WINDOWS, DOORS & OPENINGS

- All openings must be properly sealed or flashed in a manner that prevents moisture intrusion or buildup. Several examples that accomplish this are shown on the following pages.

KICK-OUT FLASHING

- Install kick-out flashing to direct the water into the gutter
- Install step flashing with minimum 4-inch upper leg
- Properly integrate flashing with the secondary water-resistive barrier. Use housewrap, flashing tape, z-flashing, or other items as needed to maintain the counterflashing principle.
- DO NOT extend the siding or trim into the kick-out flashing or gutter
- Maintain a clearance between the end of the gutter and the adjoining wall to allow for proper maintenance of the siding
- Paint ALL exposed cut edges

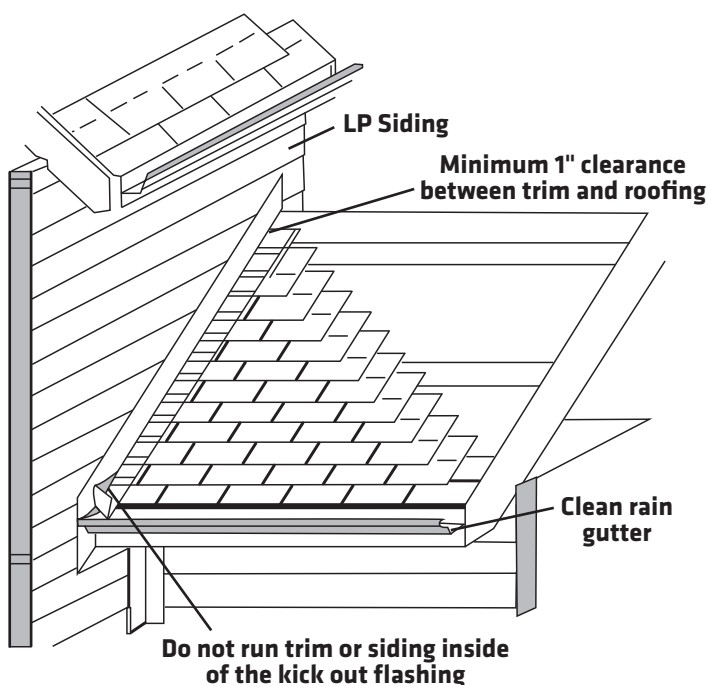

TRIM

Trim should be thick enough so the siding does not extend beyond the face of the trim.

- Trim and fascia must be applied in a manner that will not allow moisture intrusion or water buildup.
- LP® SmartSide® siding is not designed and/or manufactured to be used as trim or fascia. LP SmartSide trim and fascia are available in a variety of dimensions.

FINISHING INSTRUCTIONS

DO

- **Prime and paint all exposed surfaces including all drip edges or where water will hang.**
- Apply finish coat as soon as possible or within 180 days of application.
- High-quality acrylic latex paint, specially formulated for use on wood and engineered wood substrates, is highly recommended. Semi-gloss or satin finish oil or alkyd paints are acceptable. For flat alkyd paint, please check with the coating manufacturer for their recommendations for use on composite wood siding.
- Follow the coating manufacturer's application and maintenance instructions.

DO NOT USE

- Semi-transparent and transparent stains.
- Shake and shingle paints.
- Vinyl-based resin formulas such as vinyl acetate, PVA, vinyl acetate/acrylic copolymer paints.

SIDING APPLICATOR INSTRUCTIONS











- Architectural Collection Bold Profile 120 Series Lap Siding products are applied with the back surface flat against the sheathing and/or studs and building paper. The notched shiplapped edge provides a self-aligning system that produces a uniform appearance and weather-tight horizontal joint. Take care to align and seat all joint shelves properly.
- Apply siding over properly prepared walls or gable ends with maximum stud spacing 16 in.
- The key element in a successful siding installation is establishing a straight reference line upon which to start the first course of siding. The suggested procedure is to measure equal distances downward from the eaves and/or windows. This ensures that the siding appears parallel with the eaves, soffit, and windows, regardless of any actual setting of the house from true level.

Siding must be applied at least 6 in. above the ground. Start at the lowest corner of the house, make a starting mark at least 18 in. above the ground (6 in. ground clearance plus 11.88 in. siding width). Now, at each corner, mark a point equal to the distance down from the eaves to the starting mark. Snap chalk lines between marks and carefully apply the first course of siding aligning the top edge to the chalked reference line.

- Joint mouldings are available but not required. Nails should be placed at all stud locations and positioned 3/8 in. from the vertical butt edges on each side of the joint.

DO NOT OVERDRIVE NAILS. Nail heads should seat firmly to the face of the siding, but not overdriven to distort the siding surface. Shim as needed to avoid drawing siding against uneven walls.

Application instructions (cont.)

CONDITION		CORRECTION	
Snug		OK	
Flush		OK	
Visible fiber		Paint	
Countersunk 1/16 in.-1/8 in.		Seal with caulking	
Countersunk more than 1/8 in.		Seal with caulk and re nail	

Nail from the center of the plank toward the ends, or from one end to the other end. NEVER nail from the ends of the plank toward the middle.

NAILS MUST PENETRATE FRAMING MEMBERS AT LEAST 1-1/2 in.

For best performance use hot-dipped galvanized nails with a minimum 0.27 in diameter head and 0.113 in shank diameter.

Nail at all special framing members around openings. Shim, if necessary, to provide solid backing for siding fitted around windows, doors, and at rake cuts on gable ends.

- e) To ensure that siding courses remain level and straight, align the notched shoulder of the hidden flange prior to nailing. Additionally, make sure that the bottom edge of the siding rests firmly on top of the notched shoulder of the hidden flange. Leave a 3/16 in gap and seal at butt joints. Sealant must be a high-quality, non-hardening, paintable 30 year sealant.
- f) Where siding butts against window and door trim and at wood inside and outside corners, leave a 3/16 in gap and seal.
- g) Corner posts can be metal, wood, or vinyl. trim should be thick enough so the siding does not extend beyond the face of the trim.
- h) Use drip cap flashing above all openings to ensure a weathertight installation.
- i) LP SmartSide Architectural Collection Bold Profile Lap Siding should be sawn face up with a fine-tooth handsaw or face down with a combination blade power saw.

Insulated Sheathings

LP SmartSide Siding may be installed over low-compression rigid foam or fiberglass sheathings. The following precautions must be followed:

- a) Adequate bracing of the wall in accordance with the International Codes or other ruling building code is required.
- b) For rigid foam sheathing up to 1" (25.4 mm) thick, siding may be nailed directly to the foam sheathing unless a drainage plane is required by the local building code. Nail length must be increased to ensure a minimum 1-1/2" (38.1 mm) fastener penetration into the structural framing.
- c) For rigid foam sheathing greater than 1" (25.4 mm), a minimum 1-1/2" (38.1 mm) thick by 4" (101.6 mm) wide vertical strapping or

furring strip must be installed over the sheathing to provide a solid, level nailing base for the siding. The strapping must be securely fastened to structural framing spaced no greater than 16" OC (406 mm) with a minimum nail penetration of 1-1/2 inches (38.1 mm) and a maximum nail spacing no greater than the width of the siding.

Louisiana-Pacific will assume no responsibility for any damage or condition arising from the use of foam sheathing.

The Louisiana-Pacific Corporation ("LP") LP SmartSide Siding (the "Products") limited warranty (the "Warranty") applies only to structures on which the Products have been applied, finished and maintained in accordance with the published application, finishing and maintenance instructions in effect at the time of application. The failure to follow such application, finishing or maintenance instructions will void the Warranty as to the portion of the Products affected by the variance (the "Affected Products").

LP assumes no liability for any loss or damage sustained by the Affected Products and is expressly released by the purchaser or owner from any such loss or liability.

Any modification of the Warranty's application, finishing or maintenance requirements is void and unenforceable unless approved in writing prior to application by the Siding General Manager or his designee and a member of the LP Legal Department.

For a copy of the warranty or for installation and technical support, visit the LP SmartSide product support Web site at:

www.lpcorp.com

or for additional support call 800.450.6106.

WARRANTY REMEDIES ARE NOT AVAILABLE IF REQUIREMENTS ARE NOT FOLLOWED.

Cal. Prop 65 Warning: Use of this product may result in exposure to wood dust, known to the State of California to cause cancer.



© 2012 Louisiana-Pacific Corporation. All rights reserved. LP and SmartSide are registered trademarks of Louisiana-Pacific Corporation. Printed in U.S.A.

NOTE: Louisiana-Pacific Corporation periodically updates and revises its product information. To verify that this version is current, call 800-450-6106. LPZB0504

D5 or D8 Bold Profile

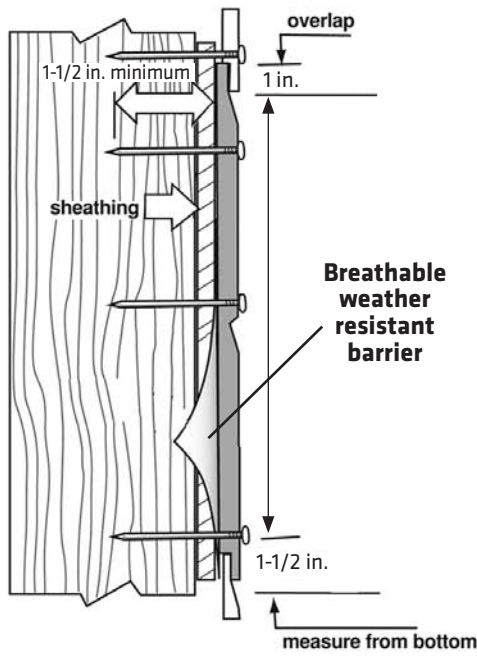

Figure 1

T4 or T5 Bold Profile

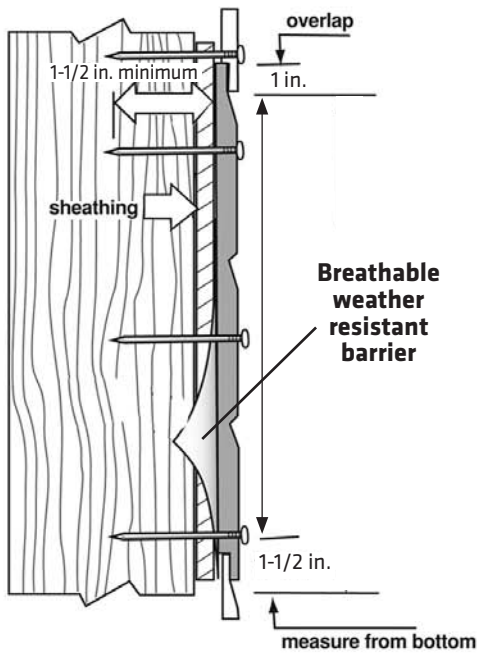

Figure 2

Q4 Bold Profile

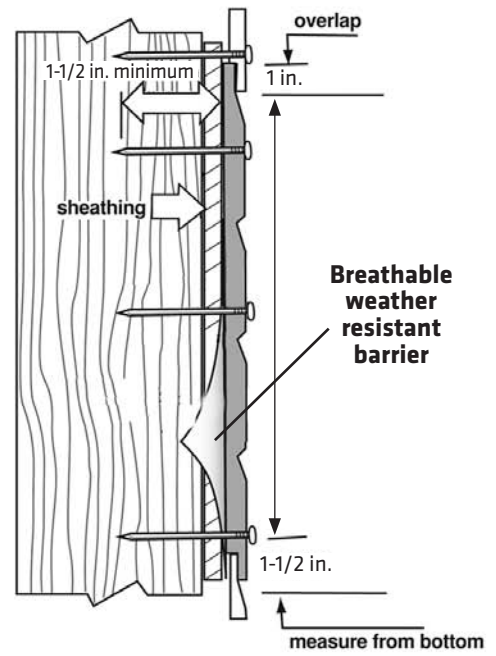
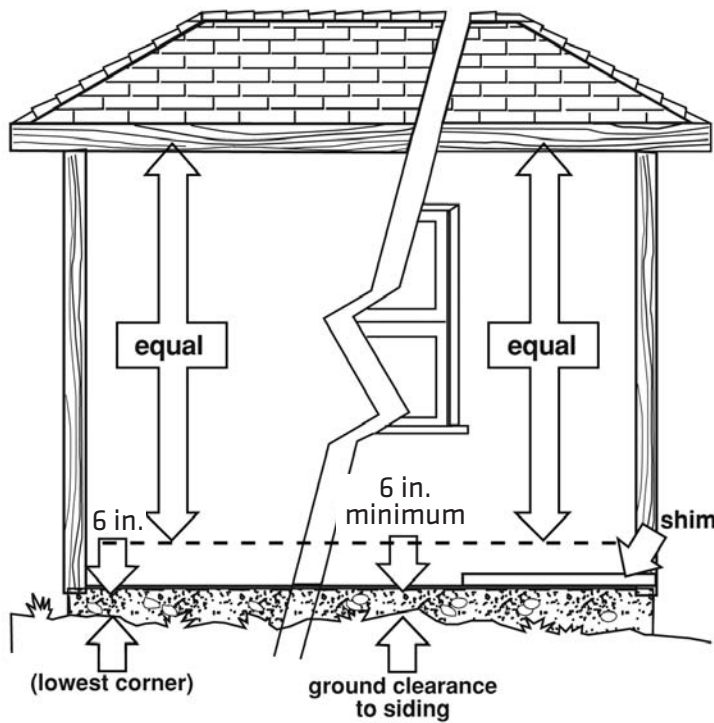
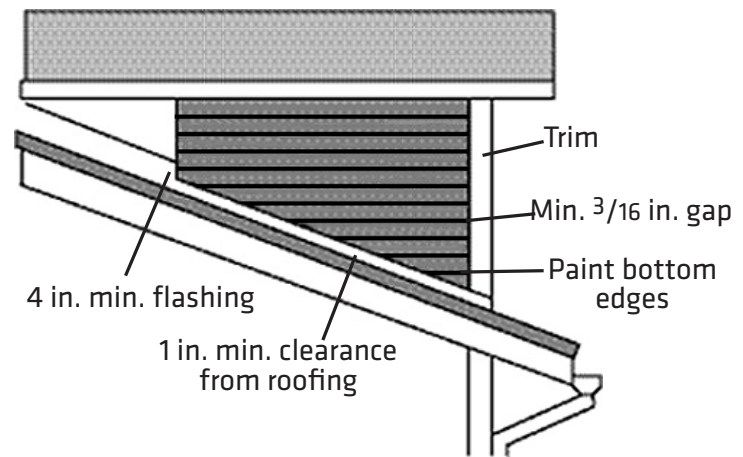

Figure 3



establish straight reference lines

Figure 4



roof flashing detail

Figure 5

Figure 2

over openings

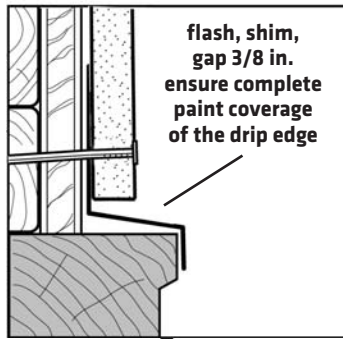

Figure 2A

alternate joint treatment

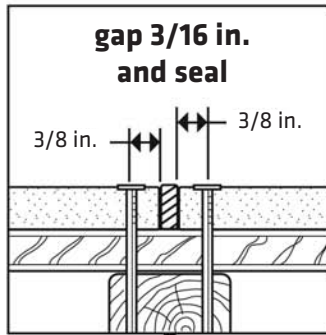

Figure 2B

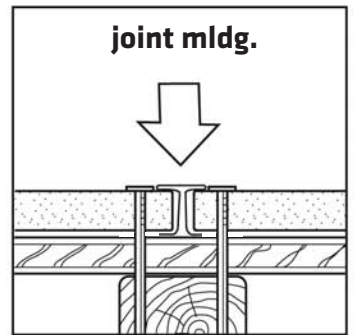

Figure 2C

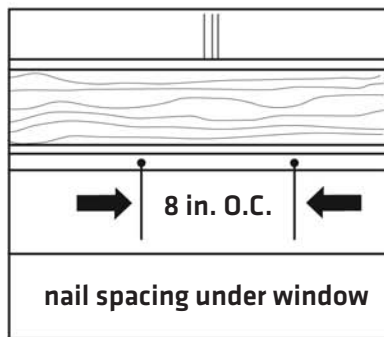
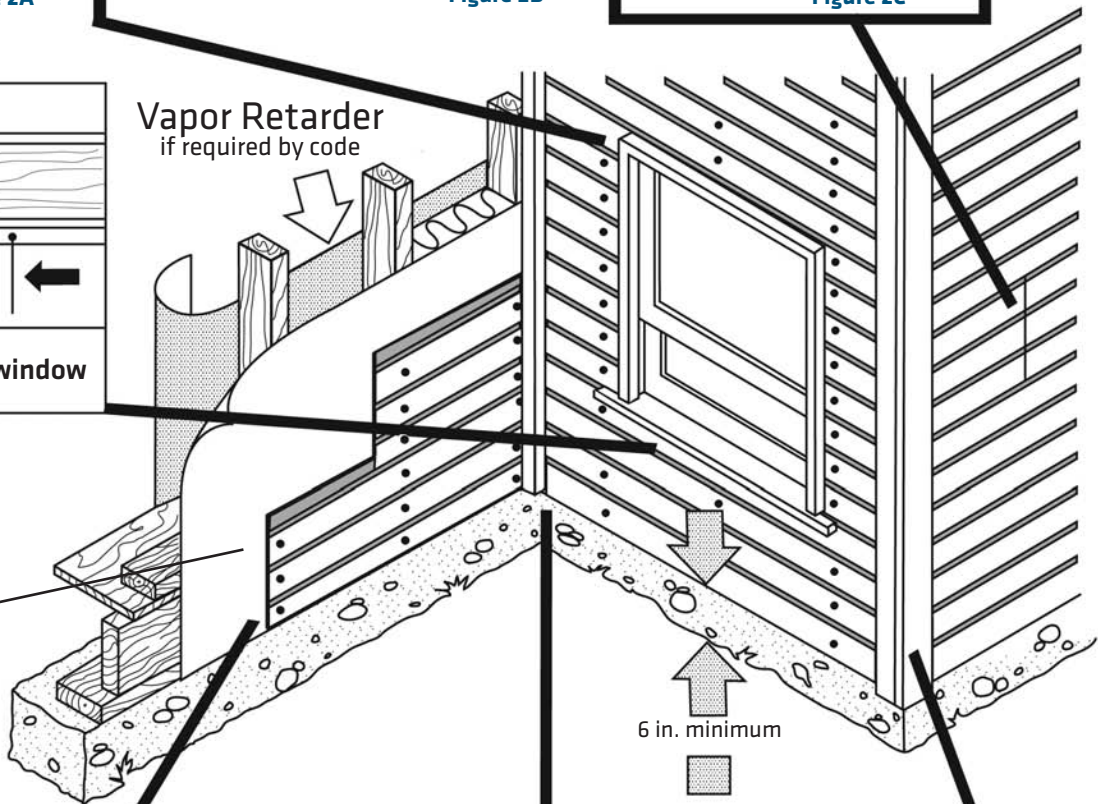

Figure 2G



Breathable weather resistant barrier

Vapor Retarder if required by code

6 in. minimum

Figure 2F

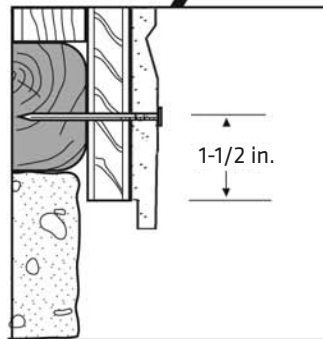

bottom course detail

Figure 2E

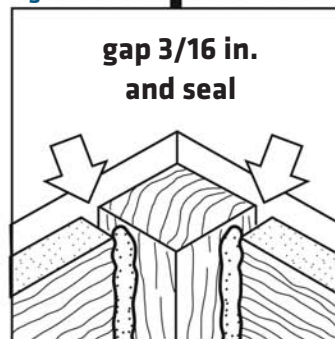

inside corner detail

Figure 2D

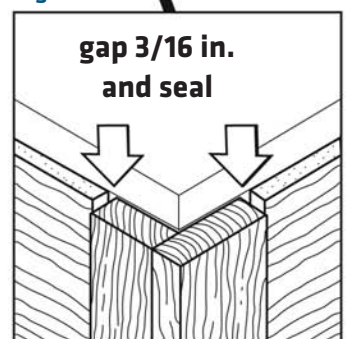

outside corner detail