



Thank you for selecting JELD-WEN products. Attached are JELD-WEN's recommended installation instructions for metal clad wood windows with nailing fin or primed wood windows with exterior trim. While the use of these installation instructions is recommended, installation in strict compliance with AAMA specifications (2400-02) is an alternate method of installation and will not affect the JELD-WEN limited warranty.

Newer construction methods have led to an increase in air and water tightness in buildings. This frequently leads to negative air pressure inside the home, which can draw water through very small openings. Our installation method integrates the window with the weather barrier of the structure (typically building wrap).

IMPORTANT INFORMATION & GLOSSARY

Not all window types may be installed into every wall condition in all areas. Consult your local building code official for applicable building codes and regulations. Local building code requirements supersede recommended installation instructions.

Please Note! These instructions do not apply to bow and bay windows and apply only to windows with a horizontal flat sill. Installations where the sill is higher than 35 feet above ground level, or any product installation into a wall condition not specifically addressed in these instructions must be designed by an architect or structural engineer. Failure to install windows into square, level, and plumb openings could result in denial of warranty claims for operational or performance problems.

Note to Installer: Provide a copy of these instructions to the building owner. By installing this product, you acknowledge the terms and conditions of the limited product warranty as part of the terms of the sale.

Estimated Install Time for New Construction	<input type="text"/>	First Time: 4.0 hr.
	<input type="text"/>	Experienced: 2.5 hr.
	<input type="text"/>	Professional: 1.5 hr.



GLOSSARY

Applied Nailing Fin

A mechanically attached vinyl fin that creates a flange around the perimeter of the window and is used to attach the window to the rough opening

Buck

A wood framework attached to the masonry inside a window or patio door rough opening.

Integral Nailing Fin

A fin that is part of the extruded aluminum cladding and used to attach the window to the rough opening.

Masonry Clip

A galvanized metal strap that secures the window to the structure.

Mulled Unit

Two or more window units structurally joined together.

Precast Sill

A pre-formed concrete block placed in the sill of a masonry/block wall to support a window.

Shiplap

The layering method in which each layer overlaps the layer below it so that water runs down the outside.

ROUGH OPENINGS

This installation guide specifically addresses masonry/block wall, sheathed wall and open-stud construction.

MASONRY/BLOCK WALL CONSTRUCTION

This installation assumes that a framework of studs (often called a buck) has already been properly fastened and sealed to the concrete/masonry wall by a building professional.

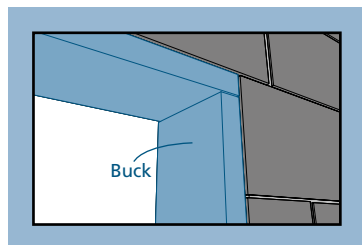

FULLY SHEATHED WALL CONSTRUCTION

The wall framing is covered by sheathing. Windows will be mounted flush against the sheathing. This installation assumes building wrap is properly installed prior to installation.

OPEN-STUD CONSTRUCTION

The wall framing must be covered by backing support before the window can be installed. The window will be mounted with the nailing fin/ exterior trim flush against the applied backing support.

This backing support should be a non water-degradable, thin (max. 1/8" thick) sheet material such as vinyl sheathing. Completely surround the rough opening with the backing support. Backing support must be applied before building wrap.

Sheathed Wall

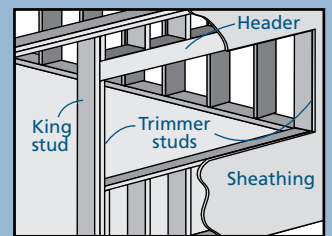

SAFETY & HANDLING

SAFETY

- Read and fully understand ALL manufacturers' instructions before beginning.
- Do not work alone. Two or more people are required. Use safe lifting techniques.
- Use caution when handling glass. Broken or cracked glass can cause serious injury.
- Wear protective gear (e.g. safety glasses, gloves, ear protection, etc.).
- Operate hand/power tools safely and follow manufacturer's operating instructions.
- Use caution when working at elevated heights.

MATERIALS AND WINDOW HANDLING

- Make sure operable windows are locked prior to installation.
- Heed material manufacturers' handling and application instructions.
- Protect adhesive surfaces from dirt, moisture, direct sunlight and folding over onto themselves.
- Handle in vertical position; do not carry flat or drag on floor.
- Do not put stress on joints, corners or frames.
- Store window in dry, well-ventilated area in vertical, leaning position to allow air circulation; do not stack horizontally.
- Protect from exposure to direct sunlight during storage.
- Install only into vertical walls and when conditions and sheathing are dry.

IF INJURY OCCURS, IMMEDIATELY SEEK MEDICAL ATTENTION!

NEEDED MATERIALS & TOOLS

NEEDED MATERIALS

Note! Follow all material manufacturers' instructions for proper use and compatibility.

- 3" galvanized casing nails (exterior trim windows) or 1 3/4" galvanized roofing nails (nailing fin windows). Nails must penetrate at least 1" into wall structure (or as required by local code)
- Galvanized drip cap (or factory supplied)
- Sealant (Protecto Wrap Protecto Sealant 25XL or equivalent)
- Polyurethane low expansion foam (Dow Great Stuff™ Window and Door or equivalent)
- Shims – not water degradable or compressible

For mulled units or windows without trim or fin on the sill:

- Masonry clips
- #8 x 3/4" screws for fastening masonry clips to the window
- #8 screws for attaching masonry clips to structure. Screws must penetrate at least 1" into framing

For installations into a stud-framed wall:

- JELD-WEN 8" drain mat material or equivalent
- JELD-WEN 4" wide self adhesive flashing or equivalent, 6" for windows rated above DP50 (9" if required by local code)
- Spray adhesive/primer (Protecto Wrap Safseal Systems 5500 or as recommended by the self-adhesive flashing manufacturer)

For installations into a buck:

- Liquid applied flashing (Protecto Wrap LWN 200 or equivalent)

TOOLS

- Utility knife
- J-roller
- Hammer
- Tape measure
- Caulking gun
- Construction stapler with 3/8" staples
- Level (4' minimum recommended)
- Drill with 1/8" tapered bit and 3/8" countersink

1 REMOVE PACKAGING & INSPECT WINDOW

REMOVE PACKAGING

Remove shipping materials such as corner covers, shipping blocks or pads. If there is a protective film on the glass, do not remove it until installation and construction are complete. Cut off any staple legs exposed on the side of the frame.

Note! Double-hung windows may have banding on the interior of the unit. Do not remove until the window is secured in the opening to help keep the sash in place and the unit square.

INSPECT WINDOW

- Cosmetic damage
- Product squareness (diagonal measurements not more than 1/4" different)

- Correct product (size, color, grid pattern, handing, glazing, energy-efficiency requirements, etc.)
- Drip cap that extends the length of the exterior trim plus 1/8" overhang on each end (all units require a drip cap); drip cap may or may not be pre-installed
- Splits, cracks, holes, missing sections or other damage to the nailing fin longer than 6" and/or within 1/2" of window frame

If any of the above conditions represent a concern, or if you expect environmental conditions to exceed the window's performance rating, do not install the window. Contact your dealer or distributor for recommendations.

2 INSPECT ROUGH OPENING

- Verify the width and height of the window are each 1/2" - 5/8" smaller than the rough opening width and height. Muller units should be 3/4" narrower.
- Verify the rough opening is square. The (A) and (B) measurements above should be the same. Maximum allowable deviation from square is 1/8" for windows 20 sq. ft. and smaller, and 1/4" for windows larger than 20 sq. ft.

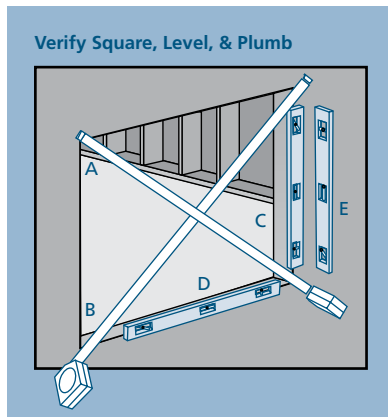

- Verify the rough opening is level and plumb (C) and (D). The maximum allowable deviation is 1/16" for every 2' of rough opening (not to exceed 1/8").
- The rough opening sill must not be crowned or sagged (D).
- The exterior face of the rough opening must be in a single plane (E) with less than 1/8" twist from corner to corner.
- Minimum double studs (king and jack/trimmer) should be used to support the header at all rough openings.

3 PREPARE BUCK

Note! This section applies to installations into a masonry wall only. For installations into a stud-framed wall, begin with section 4, "PREPARE STUD-FRAMED WALL."

1. Seal any joint larger than 1/16" in the buck and between the buck and the concrete/masonry with sealant.
2. Cover the buck and the surrounding concrete/masonry at the head and jambs with liquid applied flashing as shown.

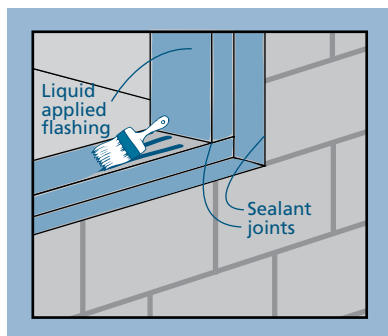

3. If installing into a four-sided buck, seal the sill in a similar manner. **Note!** Shims must be 1/4" shorter than the depth of the window sill, should level the rough opening sill and be no more than 1/4" thick.
4. Shim the sill 4" from each corner, at 8" intervals, and on both sides of mull joints with non water-degradable or compressible shims. Secure shims with sealant. **SKIP to section 5, "PREPARE WINDOW."**

4 PREPARE STUD-FRAMED WALL

FOR RETROFIT INSTALLATIONS

After removing the old window, remove sufficient siding to expose enough intact building wrap to properly seal the window to the opening. If damaged, apply new building wrap in shiplap manner. Verify the rough opening framing is structurally sound. Continue with the instructions.

PREPARE BUILDING WRAP

Note! Check with the building wrap manufacturer to verify the following steps will not void their product warranty. Follow manufacturers' instructions.

1. Trim building wrap flush with the rough opening.
2. At the head, cut building wrap at 45° and tape up as shown.

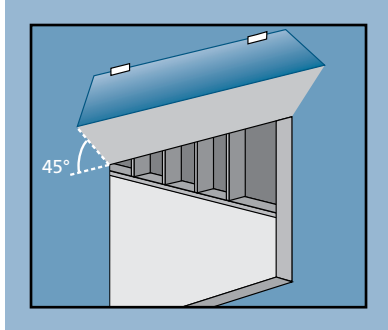

PREPARE SILL

1. Measure the width of the frame from the interior to the trim/fin and add 1/8". Transfer this measurement from the outside edge of the sill and draw a line all along the sill. This is where the back of the JELD-WEN drain mat will sit.

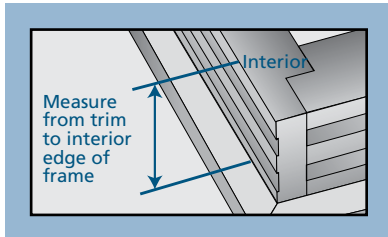

2. Cut a piece of drain mat the length of the sill plus 6".
3. Place drain mat on rough opening sill, wrapping the drain mat up 3" on each jamb as shown.
4. Pull release tape and set JELD-WEN drain mat into place.
5. Fold the drain mat down onto the sheathing. Staple drain mat to the wall and seal the corner edges as shown.
6. Smooth out any bubbles or creases with a J-roller.

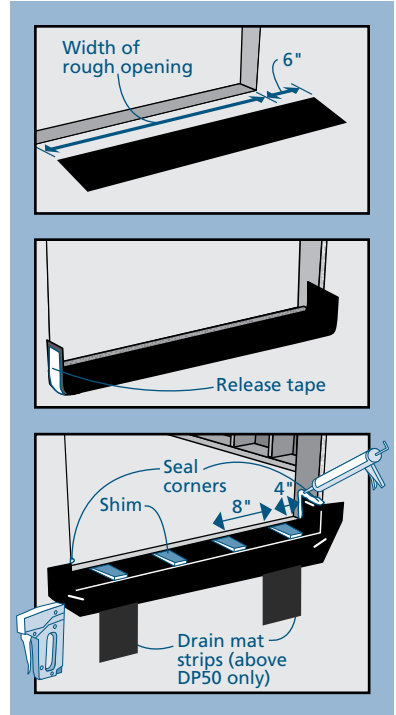

- Note!** Shims must be 1/4" shorter than the depth of the drain mat, should level the sill and be no more than 1/4" thick.
7. Shim the sill 4" from each corner, at 8" intervals, and on both sides of mull joints with non water-degradable or compressible shims. Secure shims with sealant.

8. For additional drainage for windows rated above DP50, cut a 2" wide strip of drain mat and apply vertically beneath the drain mat at 12" intervals.

5 PREPARE WINDOW

SEPARATELY SUPPLIED DRIP CAP

This step applies to nail fin units only, windows with exterior trim will install drip cap in section 6, "INSTALL WINDOW."

Lay a 1/4" bead of sealant across the header as shown, and tap the drip cap into the groove with a wood block.

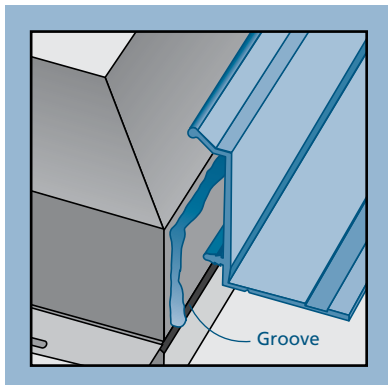

SEAL WINDOW

- For units with exterior trim: run a 3/8" continuous bead of sealant around the interior of the window where the trim meets the window frame. Tool into a fillet shape.

INSTALL MASONRY CLIPS ON THE SILL

Note! Install clips on any windows that DO NOT have exterior trim or a fin on the sill.

1. Install masonry clips 4" from each corner and every 16" on center under sill with two #8 x 3/4" screws per clip.
2. For units rated above DP50, run a continuous 3/8" bead of sealant on the interior side of the nail fin/trim where it will contact the structure.

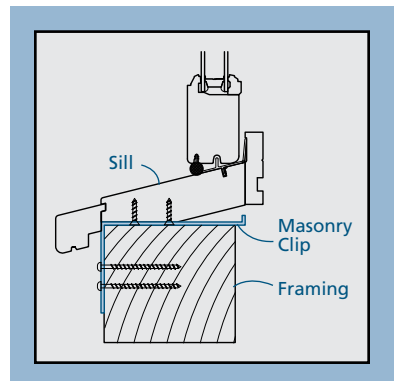

6

INSTALL WINDOW

WARNING! To avoid injury, use at least two people to install. Adequately support the window until completely fastened.

1. Place window onto the shims and tilt into the rough opening. The window sill must rest on and be supported by the shims.
2. Fasten window through the nail fin/exterior trim 3" - 7" from one lower corner.
3. Shim side jambs 4" - 6" from each corner, at the center point, and 8" apart. Shims must be set back 1/4" from the interior of the jamb as shown. Secure with sealant.
4. Inspect window for square, level, and plumb. Test for proper operation (remove and reinstall if necessary).

Note! Fastener heads must be flush. Do not dent nailing fin or damage exterior trim.

5. Fasten window through the exterior trim/fin 4" from the corners and 8" apart all the way around the window.
6. If applicable, install two #8 screws through each masonry clip and into the framing. Screws must be long enough to penetrate framing by at least 1".

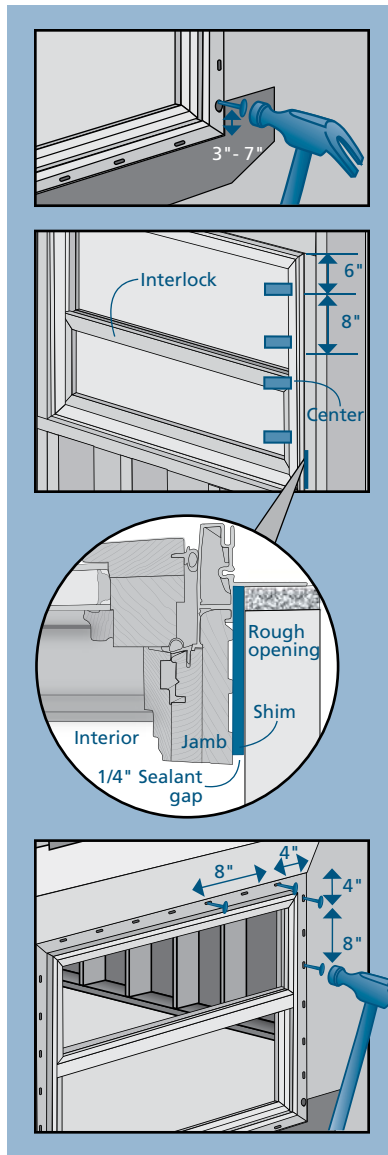

7. Hung windows must be fastened through the jamb adjusters with #8 x 2" screws provided. Straighten the jambs per the instructions provided with the screws.
8. Windows rated for DP50 or above (including impact) must be fastened through the jambs and head 4" from each corner and at 8" intervals with #8 x 3" screws as shown. Screws must penetrate shims.

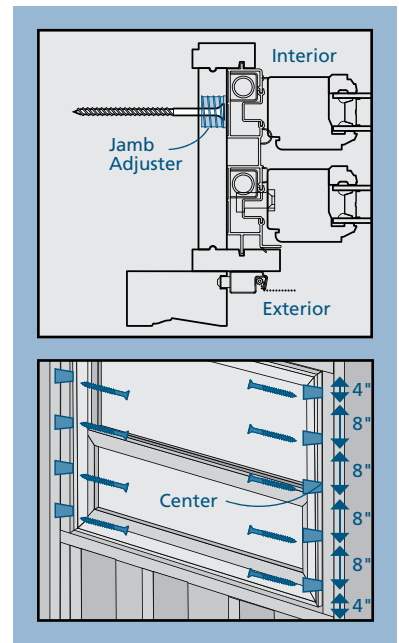

APPLY DRIP CAP TO WINDOWS WITH EXTERIOR TRIM

1. Cut a piece of drip cap the length of the header trim + 1/4" to allow for 1/8" overlap past the ends of the trim.
2. Apply 1/4" bead of sealant to header trim as shown.
3. Center the drip cap on the trim and nail in place as shown.
4. Apply sealant underneath the drip cap where it meets both ends of the trim.

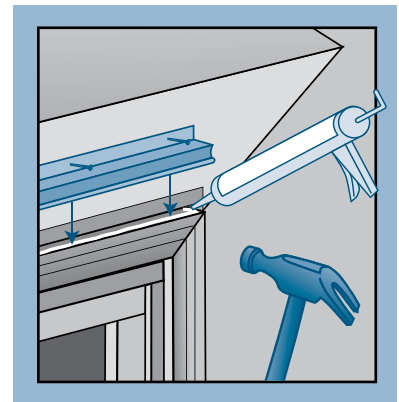

7

FLASH WINDOW - WINDOWS WITH A NAIL FIN INSTALLED INTO STUD-FRAMING ONLY

Cut pieces of self-adhesive flashing as follows:

	DP50 or below (4" flashing)	Above DP50 (6" flashing)
One header piece	10" longer than the header	14" longer than the header
Two side pieces	7" longer than the jamb	10" longer than the jamb
One sill piece	N/A	6" longer than the sill

SPRAY ADHESIVE/PRIMER

Apply spray adhesive (protect window from overspray) to nailing fin and building wrap around the window as shown.

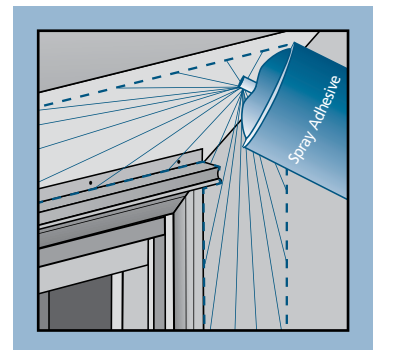

7

FLASH WINDOW - CONTINUED

APPLY THE SELF-ADHESIVE FLASHING

Note! Keep the edge of the JELD-WEN self-adhesive flashing as close to the window frame as possible and apply over the nail fin.

1. If installing a window rated above DP50, center and apply 6" wide flashing below the sill.
2. Apply the side pieces starting 2" above the header and overlap the drain mat on the sill as shown.

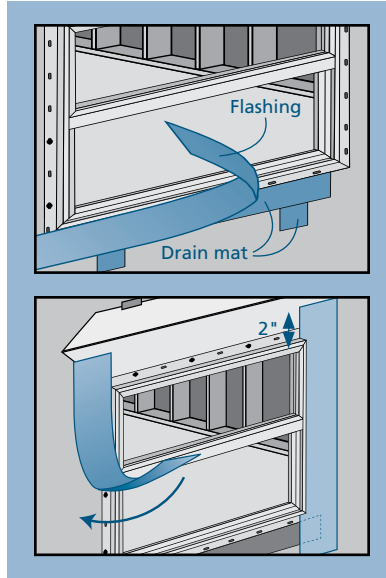

3. Center and apply the header piece above the header, overlapping the side pieces as shown.
4. Press the flashing down with a J-roller, being careful to remove any gaps or bubbles beneath self-adhesive flashing (remove and replace if necessary).

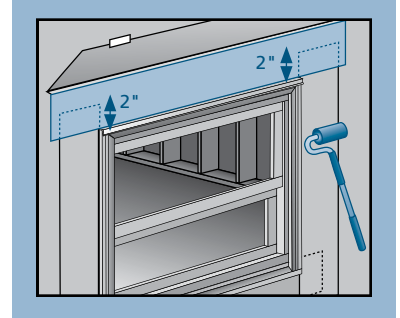

8

COMPLETE INSTALLATION

1. Release the building wrap from above the header (previously taped up) and overlap the header flashing. Seal the ends with self-adhesive flashing or building wrap tape.
2. Seal all four corners of the window with a 3/8" bead of sealant. Tool into a fillet shape.
3. Seal any gaps or openings at end of horizontal mull joints with sealant.
4. Create a continuous air seal on the interior between the rough opening and the window frame with low expansion polyurethane foam or backer rod and sealant. On the sill, the foam or sealant must create this air seal by integrating the back of the drain mat with the window frame and the rough opening.

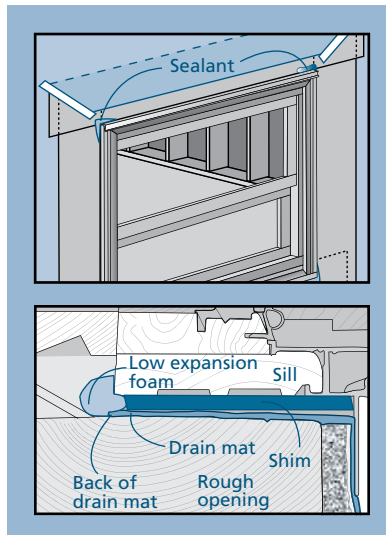

AFTER INSTALLATION

- Install exterior wall surface within 30 days of window installation.
- Maintain gap of 1/4" - 3/8" between window frame and final exterior wall surface.
- Adjust window for best operation.
- Remove protective film from cladding (if present) immediately after installation; remove from glass within one year.
- Protect recently installed units from damage from plaster, paint, etc. by covering the unit with plastic.
- Finish all exposed wood surfaces immediately following installation.

Please visit jeld-wen.com/resources for warranty and care and maintenance information.

Thank you for choosing

