



Installation Instructions



Vinyl Mounting Flange (Nailing Fin) Window

ROUGH OPENING PREPARATION

1. Rough opening should be sized one-half inch (1/2") larger than the window size in width and height. Provide a minimum of one-quarter inch (1/4") clearance at the top (head) and one-eighth inch (1/8") clearance on each side (jamb) of the unit. Improperly sized rough openings will not allow the window to function as was intended.

2. Sheathing must be installed around the perimeter of the rough opening before window installation for the attachment of flashing. Flashing materials must meet a minimum water resistance of 24 hours in accordance with ASTM-D779 and be a minimum of nine inches (9") wide. GA recommends the use of appropriate self-adhering flashing. All notations on flashing placement and installation are based on the use of appropriate nine inch (9") self-adhering flashing.

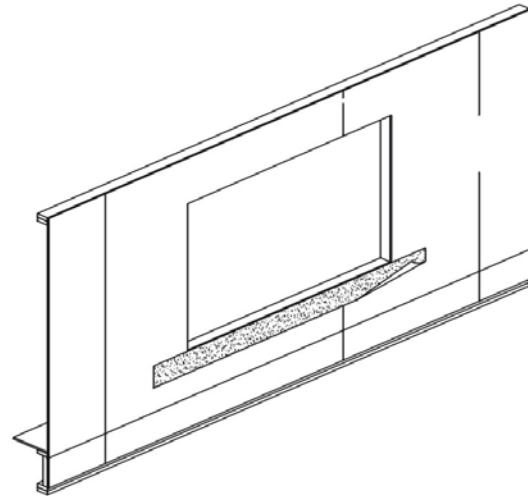

3. Attach a strip of flashing material horizontally along the bottom face (sill) of the rough opening. Sill flashing length should be equal to the rough opening width plus two times the flashing width. The sill flashing should be long enough to extend nine inches (9") beyond both jambs of the rough opening.

4. Regarding building sequence, the roof should be installed before windows are installed. This will prevent any problems from header deflection. If windows are installed before the roof loads have been applied and the header deflects, serious problems such as stress cracks and window frame deflection may occur which will void the window warranty. If windows must be installed before the roof loads have been applied, then the size of the headers must be large enough to limit the amount of deflection.

WINDOW PREPARATION

5. The operable sash of the window must remain closed and locked during the entire installation process.

6. Apply a three-eighths inch (3/8") nominal continuous bead of sealant to the interior perimeter of the mounting flange (nailing fin) in line with the pre-punched holes and along the seams of all joints at the corners. It is important to properly select and apply sealant. Refer to

ASTM standards C1193 and C1299 for information on sealant selection and use. If in doubt about compatibility, use a silicone or polyurethane sealant rated to ASTM C920 Class 25.

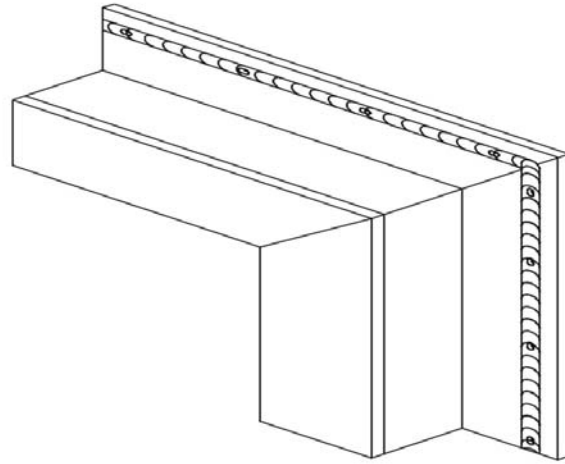

WINDOW INSTALLATION

7. Immediately set the window centered in the rough opening and compress the sealant against the sheathing.

8. Select and apply shims as necessary. The proper number and position of shims is important. Position shims where support is needed but do not over, or under, shim as either can cause distortion of the window frame. If shims are needed at the sill, use continuous support across the entire bottom (sill) of the window to prevent any warping, sagging or crowning.

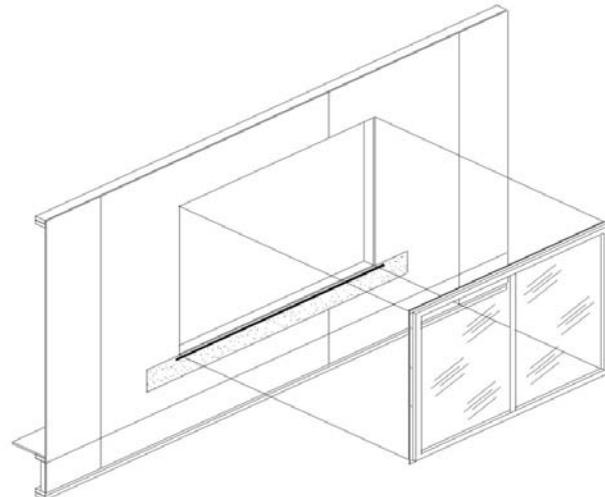

9. Fasten (tack) upper corner on the side (jamb), not the top (head), in place through the mounting flange (nailing fin) three inches (3") from the corner using an appropriate fastener that will penetrate the stud one inch (1"). DO NOT DRIVE THE FASTENER ALL THE WAY IN.

10. Adjust the shims and check the window for level, plumb and true.

11. Make sure the window is square, operates smoothly, the operable sash is square in its opening and the latches are able to engage.

12. Fasten (tack) the corner diagonally opposite the upper corner that was tacked first on the side (jamb), not the bottom (sill), in place through the mounting flange (nailing fin) three inches (3") from the corner using an appropriate fastener that will penetrate the stud one inch (1"). DO NOT DRIVE THE FASTENER ALL THE WAY IN.

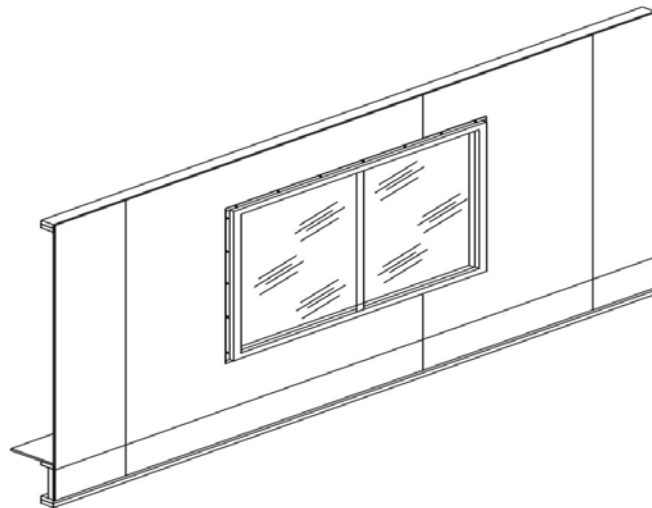

13. Check the window for level, plumb and true. Make sure the window is square, operates smoothly, the operable sash is square in its opening and the latches are able to engage.

14. Drive the fasteners, which were previously tacked, all the way in being careful to avoid compressing or distorting the mounting flanges (nailing fins).

15. Continue to fasten the sides (jamb), top (head) and bottom (sill) by placing a fastener in every or every other pre-punched hole in the mounting flange (nailing fin). Do not place a fastener within three inches (3") of any corner. Avoid compressing or distorting the mounting flanges (nailing fins). High Impact power fastening equipment should not be used for installation. **UNDER NO CIRCUMSTANCE SHOULD THE HEAD OF THE FASTENER DISTORT OR PENETRATE THE MOUNTING FLANGE (NAILING FIN).** If the joints or corners of a mounting flange (nailing fin) are bent, broken or cracked during or prior to installation, the installer is responsible for repairing the damage.

16. Recheck the window for level, plumb and true. Make sure the window is square, operates smoothly, the operable sash is square in its opening and the latches are able to engage.

FLASHING INSTALLATION

17. Attach strips of flashing material vertically along the left and right face (jamb) of the rough opening over the window mounting flanges (nailing fins). Jamb flashing length should be equal to the rough opening height plus two times the flashing width minus one inch (1"). The jamb flashing should be long enough to extend eight-and-one-half inches (8 1/2") beyond the head and sill of the rough opening over the sill flashing. Apply the flashing vertically over all pre-punched holes and fastener heads, being sure to seal any penetrations or voids.

18. Attach a strip of flashing material along the top face (head) of the rough opening over the window mounting flange (nailing fin). Head flashing length should be equal to the rough opening width plus two times the flashing width plus two inches (2"). The head flashing should be long enough to extend ten inches (10") beyond the jambs of the rough opening over the jamb flashing.

Note: All notations on flashing placement and installation are based on the use of nine inch (9") self-adhering flashing.

FINISHING THE INTERIOR

19. Place loose bat-type or mineral fiber insulation in the cavity between the window frame and rough opening. Do not over-pack the insulation because it may distort the window frame and adversely affect the performance of the window. **THE USE OF EXPANDING FOAM-TYPE INSULATION IS**

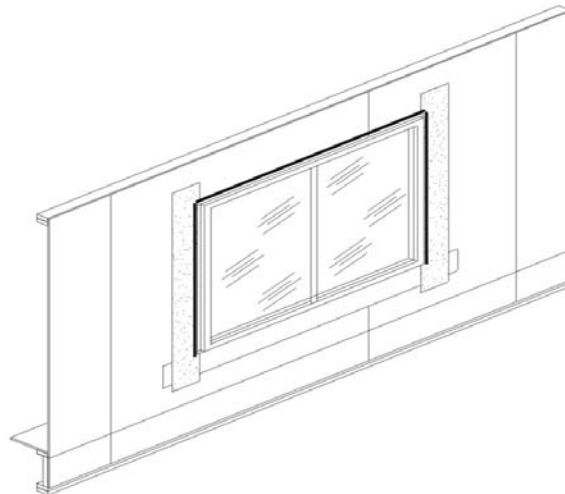

NOT RECOMMENDED.

20. Insulation is not necessary if the gap between the window and the rough opening can be filled with sealant (a gap of 1/4" or less).

NOTICE ABOUT EXPANDING FOAM PRODUCTS: The use of any expanding foam-type insulation is not recommended around any GA products. Doing so may cause damage and void the product warranty. If expanding foam-type insulation must be used, always follow the foam manufacturers' instructions for application to avoid excessive expansion of the foam and distortion of the window frame.

FINISHING THE EXTERIOR

21. After the exterior façade (brick, stucco, siding, etc.) is completed, a perimeter sealant joint must be placed around all window openings. The perimeter sealant joint prevents air and water from entering between the window and the exterior building materials.

22. Perimeter sealant joints should be at least one-quarter inch (1/4") wide and be backed-up with backer rod or bond breaker. Backer rod should be one-third (1/3) larger in diameter than the nominal width of the joint.

23. Weep holes should be left in the perimeter joint at the head of the window opening to allow water to escape from above the opening. Any water that penetrates the exterior façade (brick, stucco, siding, etc.) must be allowed to drain, so always coordinate the perimeter sealant joint with the contractor.

24. Use caution to avoid covering any window weep holes with sealant, paint or any other obstructive material

CLEANING THE WINDOW

25. Start cleaning the window by removing any visible residue. Clean and clear all excess building materials, such as plaster, cement, soil, paint and excess caulk/sealant, from the window to ensure proper functioning. A vacuum cleaner should be used to remove loose debris and drywall dust from the window track and interlock.

26. Inspect and clean all weepholes to ensure proper drainage of the window.

27. A mild detergent cleaner can be used along with a soft sponge to gently scrub the surface of the window, if soil still adheres. Mild detergent deemed safe for bare hands should be safe to use on vinyl windows. **ABRASIVE PADS SHOULD NOT BE USED TO CLEAN FINISHED SURFACES. NEVER**

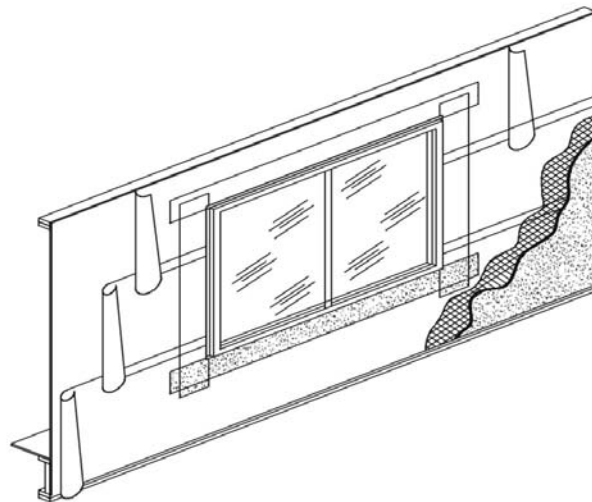
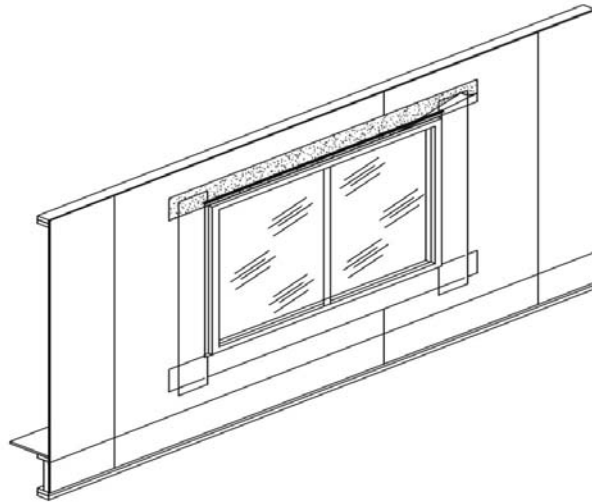

USE PAINT REMOVERS, AGGRESSIVE ALKALINE, ACID OR ABRASIVE CLEANERS. DO NOT ATTEMPT TO CLEAN SUNHEATED SURFACES WITH CHEMICAL AGENTS AS POSSIBLE CHEMICAL REACTIONS ON HOT SURFACES MAY BE ACCELERATED. USE ONLY MILD DETERGENTS AND NONETCHING CLEANING AGENTS ON WINDOWS.

28. For cleaning glass use a mild detergent or specialized glass cleaner. GLASS SHOULD NEVER BE CLEANED WITH AN ABRASIVE MATERIAL OR STRONG ORGANIC SOLVENTS AS THEY WILL HARM THE GLASS SURFACE AND/OR GLAZING SEALANT.

29. Do not use diesel fuel, kerosene, oil or any hydrocarbon fuel (wax) for cleaning any part of the window.

30. Do not use power washing equipment for cleaning or washing the window.

31. Windows arrive at the job site with labels and stickers on the surface. Temporary labels may be removed at the cleaning stage of construction. Temporary labels are applied to the glass. Always consult your local building code official for instructions as to when temporary labels can be removed. Permanent labels such as the AAMA label should not be removed. Permanent labels are located in inconspicuous locations such as the head or jamb track.

MAINTAINING THE WINDOW

32. The operable sash may need cleaning and/or minor lubrication occasionally to ensure smooth operation. Tracks should be vacuumed and cleaned regularly to remove loose debris and dust. If lubrication is needed, verify that the lubricant is compatible with vinyl and plastic parts used in the window assembly.

33. If the operable sash on a hung window lifts or settles improperly, the balance system may need to be adjusted. A GA representative or dealer should be contacted for proper instructions on the balance adjustment process. Balances should only be adjusted with the proper tools to avoid possible injury to oneself or the window.

34. Window screens are intended to provide reasonable flying insect control and are not for the purpose of preventing all crawling or flying insects from entering an open window. There are insects small enough to pass through the window screen material and/or crawl around the screen frame. Screens do not provide security.

35. SCREENS ARE NOT A RESTRAINING DEVICE FOR CHILDREN. DO NOT LEAVE CHILDREN UNATTENDED WHEN THE WINDOW IS OPEN OR UNLOCKED. SCREENS ARE EASILY REMOVED FROM INSIDE AND ARE NOT DESIGNED AS A SAFETY RESTRAINT.

[Return to Top](#)

Back

[Return to previous page](#)